

LOC	DIST	P	F	ZONE	LTR	DESCRIPTION	DATE	APPD
AD	14							
					F	REDRAWN PER AD-5103 & ADDED -3 PER 91-5283-001	3/91	MB
					G	REVISED PER AD6120	4/28/92	MB
					H	REVISED PER AD6367	4/28/92	MB
					J	REACTIVATED -3 PER 91-5283-001	12/21/92	MB
					K	REVISED PER 0010-0072-96	5/16/96	RB MB
					L	REVISED PER 0010-0825-96	12/3/96	RB MB

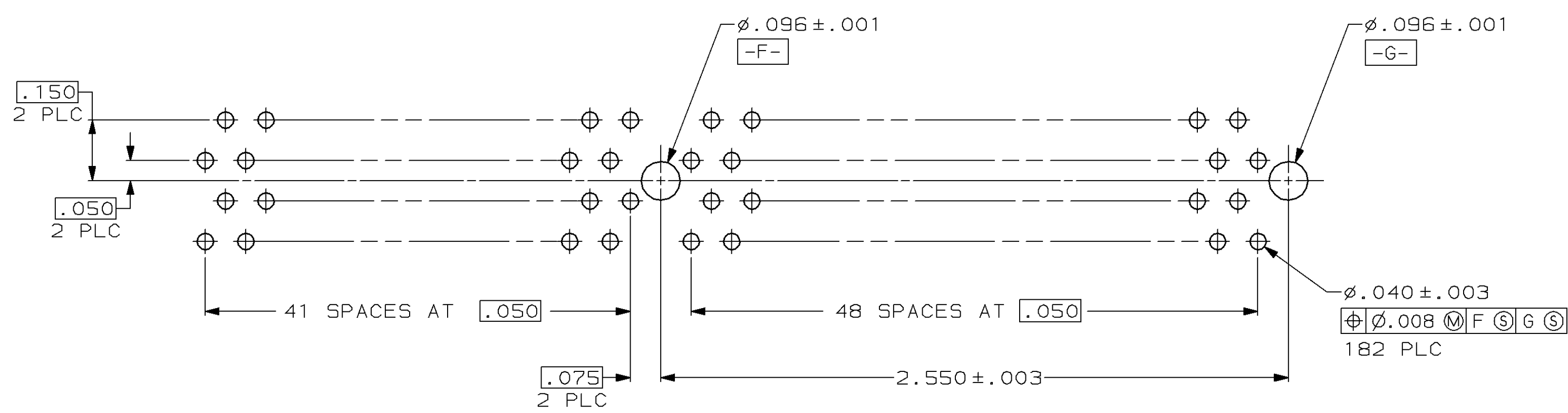

RECOMMENDED CONNECTOR MOUNTING HOLE PATTERN  
 (CONNECTOR SIDE SHOWN)

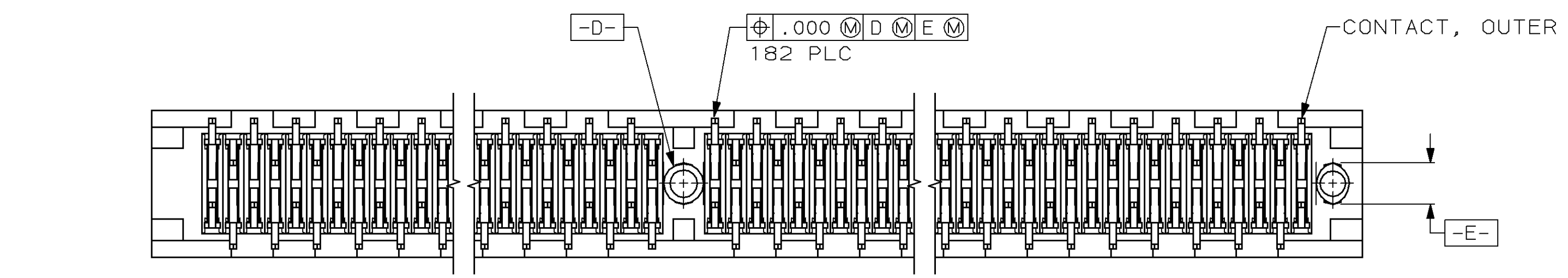
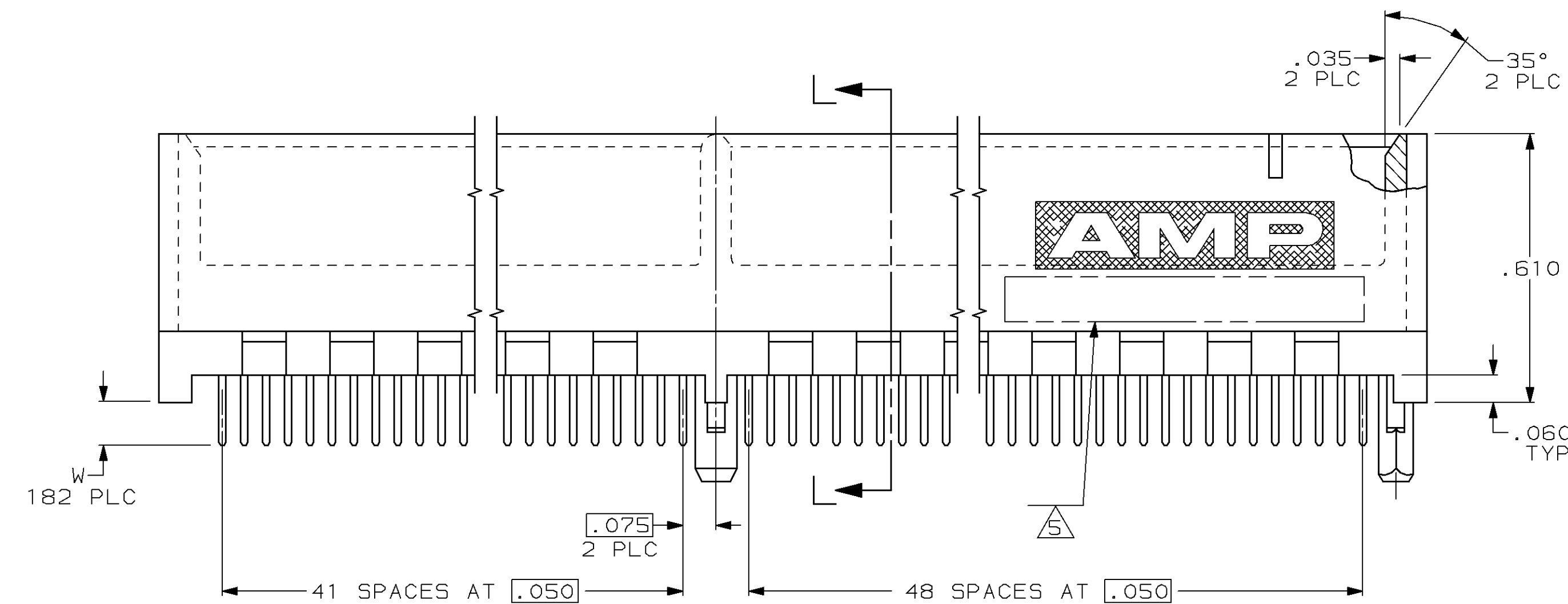
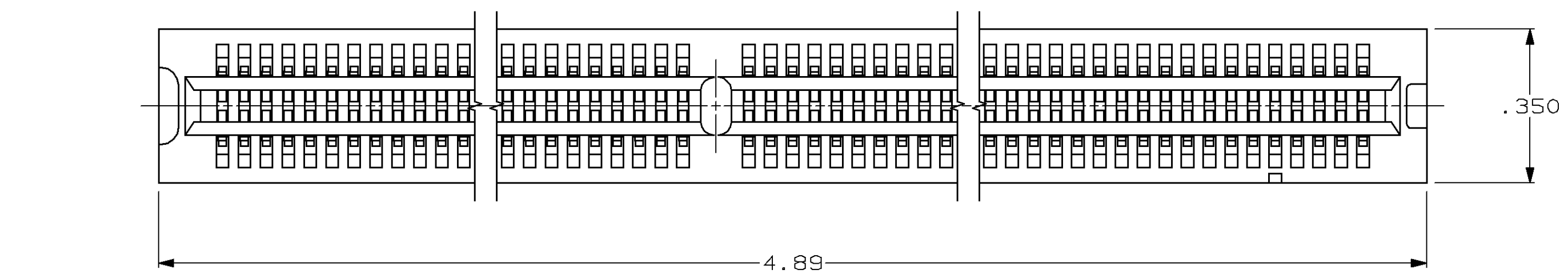
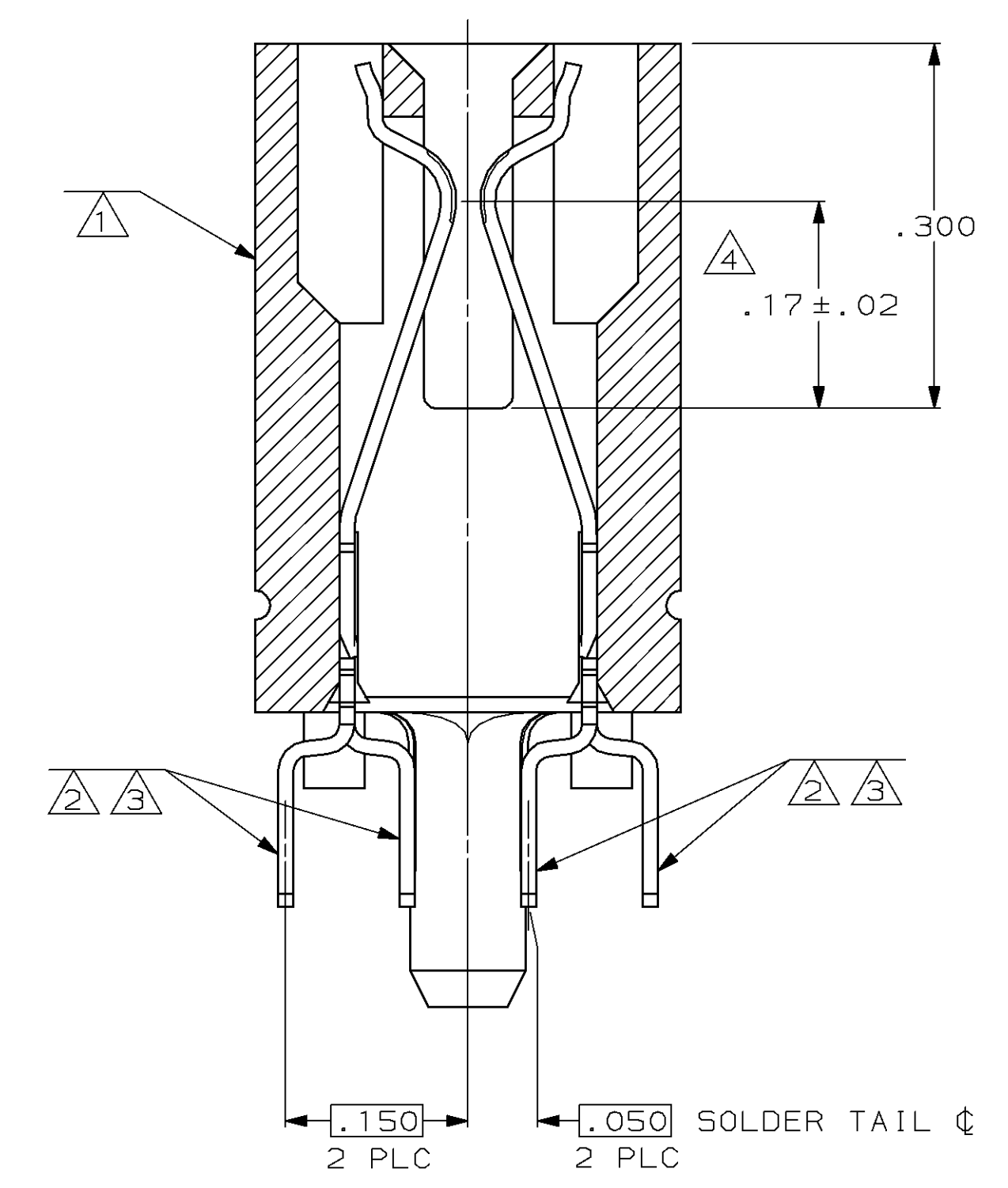

SECTION L-L  
 SCALE 8:1

- 1 HOUSING: HIGH TEMPERATURE THERMOPLASTIC. COLOR: BROWN.
- 2 CONTACT: PHOSPHOR BRONZE.
- 3 CONTACT FINISH: .000100 MIN NICKEL ALL OVER. .000030 MIN GOLD OVER NICKEL IN CONTACT AREA. .000100 MIN TIN-LEAD OVER NICKEL ON SOLDER TAILS.
- 4 DISTANCE FROM CONTACT POINT TO BOTTOM OF CARD SLOT.
- 5 AMP PART NUMBER, DATE CODE AND CSA LOGO MARKED IN APPROXIMATE AREA SHOWN.

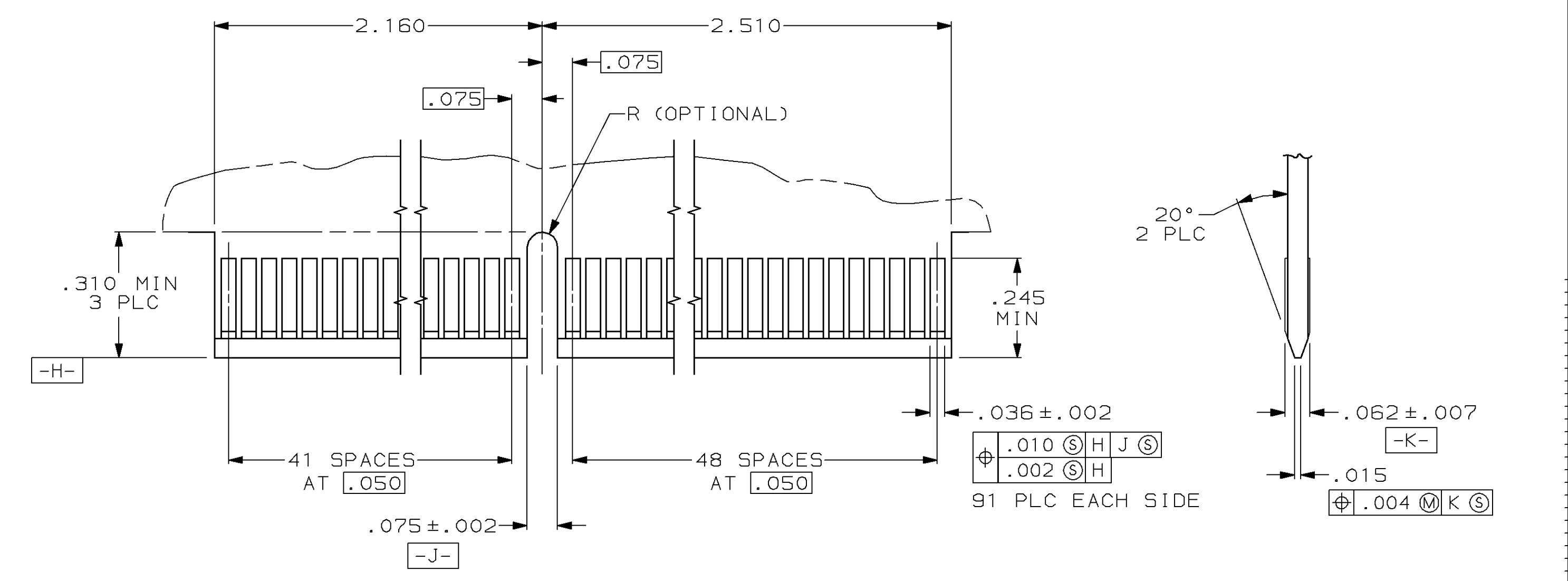

RECOMMENDED MATING BOARD EDGE CONFIGURATION

OBSOLETE	.125	650092-3
	.14	650092-2
	.10	650092-1
	W	PART NUMBER

DO NOT SCALE PRINT. UNLESS SPECIFIED DIMENSIONS IN mm [INCHES] TOLERANCES ON: 2 PLC DEC ± .01 3 PLC DEC ± .005 ANGLES ± 2°		DR 3/21/91 K.L.CLOUSER/UTA		AMP Incorporated Harrisburg, PA 17105-3608	
MATERIAL HOUSING: 1 CONTACT: 2		CHK 7-22-91 M BOWERS			
FINISH CONTACT: 3		APPD 7-23-91 M THUMMA		NAME CONNECTOR ASSEMBLY, 91 DUAL POSITION, .050 SERIES, STANDARD EDGE	
APPLICATION SPEC 114-26012		PRODUCT SPEC 108-14034		SIZE D	
WEIGHT		DRAWING NO 650092		CAGE CODE 00779	
		SCALE 4:1		SHEET 1 OF 1	